



AKG Thermal Management System – Compact Module

The AKG Thermal Management System for electric vehicles is designed to regulate and maintain optimal temperature conditions for batteries, ensuring their efficient operation, long lifetime and reliable power. Our system is designed for off-road and on-highway applications.

With a compact and modular design, our Thermal Management System is easily integrated in many types of equipment. The battery is cooled using a closed refrigerant circuit and can optionally be heated with an electrical high voltage heater. An on-board controller manages the complete thermal system operation.

Our heat exchangers play a crucial role in transferring the absorbed heat through the cooling medium to the refrigerant and the surrounding environment. AKG's design and placement of the heat exchangers within the Thermal Management System are optimized to maximize cooling effectiveness while minimizing energy consumption.

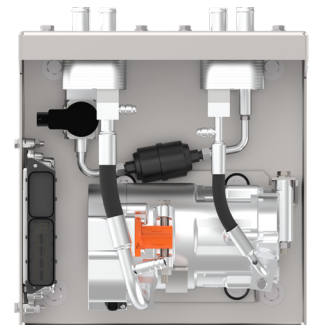
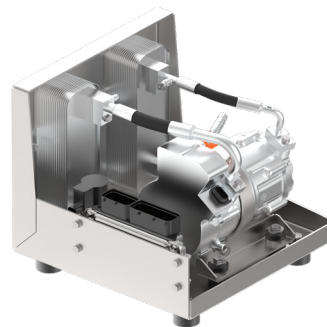
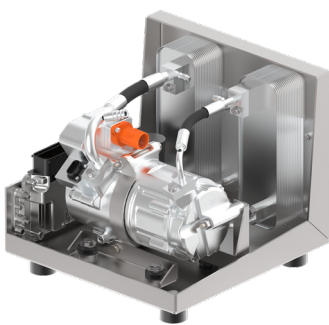

AKG Thermal Management System – Compact Module

Benefits



1. Modular design

- Pre-assembled modules, no individual parts need to be integrated into the vehicle
- Flexible to customer requirements



5. Global product portfolio

- AKG's diversified product portfolio offers all heat exchangers types needed for the vehicle



2. Closed-loop refrigerant circuit

- Low maintenance; no additional refrigerant lines to the vehicle needed



6. AKG stacked shell cooler

- Optimally designed for Thermal Management Systems with less weight and high performance



3. Simulation

- Simulations at the component and system level speed up the vehicle development on the customer's side



7. AKG engineering service

- Comprehensive engineering support regarding the integration of Thermal Management Systems into the vehicle architecture



4. Robustness

- Same performance verified under different inclinations and robustness confirmed in vibration tests



8. Environmental friendly

- Low refrigerant volume means the use of natural refrigerant (propane/R290) is possible

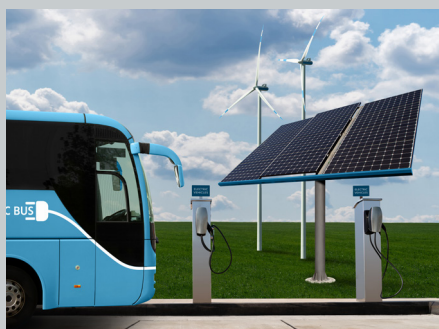

Applications – Markets



Agricultural equipment



Forestry equipment



Automobile



Generator set



Commercial vehicle



Municipal vehicles



Construction equipment



Battery storage



AKG Thermotechnik International GmbH & Co. KG

Am Hohlen Weg 31
D-34369 Hofgeismar • Germany
Phone + 49 5671 - 8 83 - 0
Mail info@akg-group.com

