

Solutions for a Sustainable Future



 **AKG Green**  
Thermal Solutions.



## AKG Green Thermal Solutions.

### AKG Green Thermal Solutions

AKG – efficient cooling systems contributing to a greener and sustainable world



AKG supports the decarbonization of the global economy with efficient cooling and thermal management systems for alternative drive concepts and clean energy in selected industries, such as wind energy, electronics and fuel cell cooling. It has always been our goal to improve thermal solutions, starting in 1919 with automotive cooling over the recent past with the cooling of combustion engines in different applications until today's Green Thermal Solutions. We believe that we can support our customers all over the world to meet their "net-zero" emission targets. AKG Green Thermal Solutions is our approach to help creating a sustainable future.

### Sustainable Mobility

Our Thermal Management System is an innovative solution that increases battery life by maintaining the optimum temperature needed for the battery. Heating and cooling modes ensure a complete thermal control for all of the temperature sensitive components built into the vehicle. The thermal management of the complete system includes the battery, E-motor, power electronics, transmission system, driver's cabin and much more. We are working closely with our customers and partners for prototypes, validation and global manufacturing. With our optimal cooling and heating solutions, we not only increase the safety but also the range of electrified vehicles and thus contribute to a more sustainable future mobility.



### AKG Solutions for a Sustainable Future

- Thermal Management System
- Fuel Cell Cooling System
- Hybrid systems with Fuel Cell & Battery TMS
- Battery Cooling
- Electronics Cooling

## Thermal Management System for Electric Vehicles

Maintaining the optimum temperature of the battery and further temperature sensitive components can be done either with our chiller or with our heat pump system. The chiller is using an air-cooled condenser and an optional high voltage heater. With our heat pump system and the intelligent controlling, we are able to reduce the energy consumption by 15-30% and thereby reduce battery size or significantly extend the driving range / working time especially in cold weather conditions.

## Cooling Solutions for Fuel Cell Vehicles

AKG's lightweight and high performance heat exchangers deliver excellent cooling and heating performance for direct or indirect thermal management of fuel cell applications. To meet the conductivity requirements, our heat exchangers can be vacuum brazed and de-ionized. The special de-ionization process can also be used for further brazing options to meet the conductivity requirements.

## Hybrid Cooling System

We see the hybrid system as a combination of a battery electric drivetrain together with either an internal combustion engine or a fuel cell system. The energy produced by the internal combustion engine or the fuel cell will be used for the drivetrain and/or for charging the battery, which enables the hybrid vehicle to have a higher range than a battery electric vehicle. Due to the various amount of cooling components, we are always looking for synergies of both systems and therefore the highest overall efficiency.

## Battery Cooling

The battery is the major component of an electric vehicle and keeping the right temperature is essential for its lifetime, performance and safety. To maintain the optimal temperature range, we have several different design approaches to cool or heat each cell individually. This can be either top- and bottom cooling, side cooling or extensive surround cooling. With our design flexibility, we are able to adjust performance and pressure drop to suit your requirements perfectly.

## Electronics Cooling

Power electronics are inevitable in most modern systems, such as inverters and converters for renewable energies as well as electric drivetrains. Even though the efficiency is very high, there are still local heat loads, which need to be cooled to achieve a better performance and longer lifetime. With our product portfolio in electronics cooling and many years of proven and optimized design, we are able to achieve a high performance and homogenous low temperature for the sensitive power electronics.



## Thermal Management System for Electric Vehicles

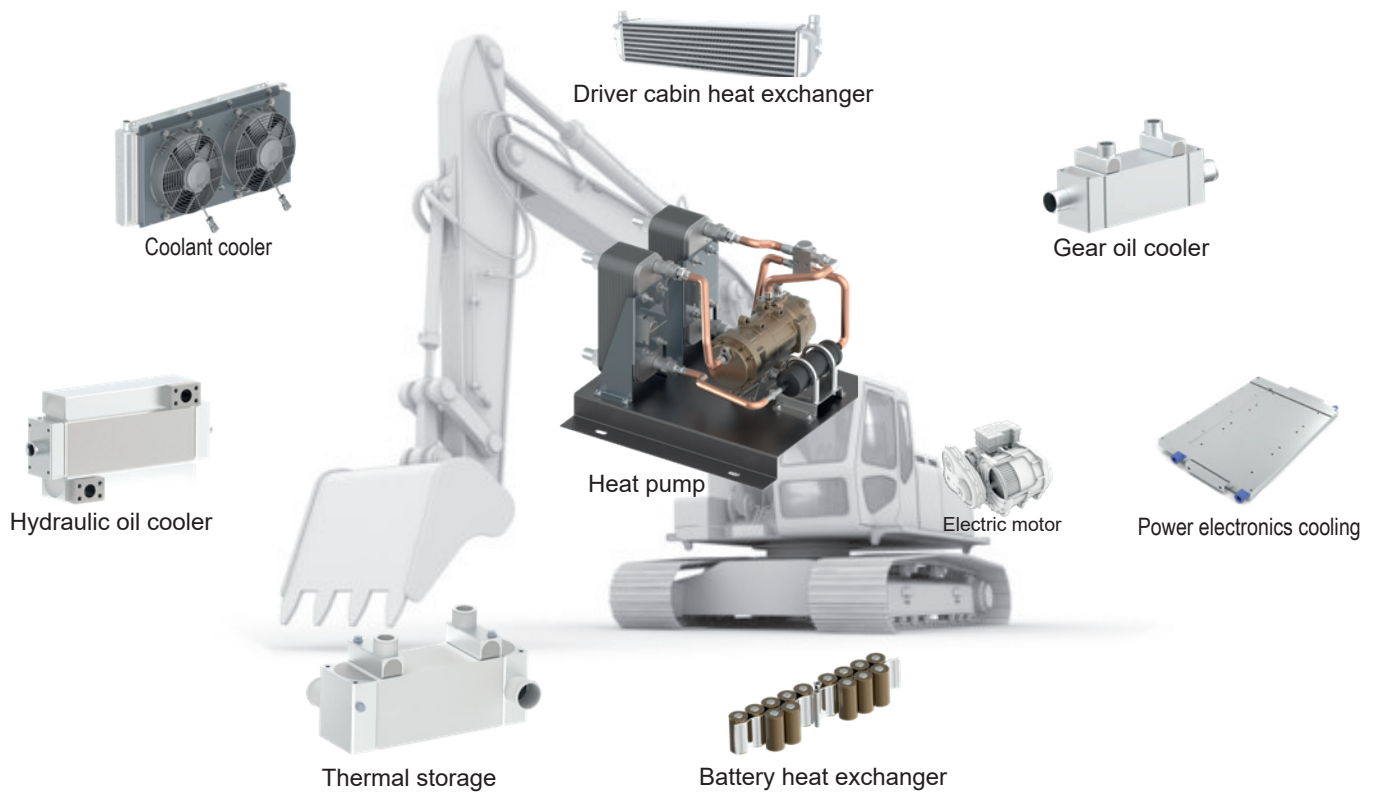

AKG's lightweight and robust coolers are a perfect fit for the electro mobility applications that demand high performance and less weight. With a diversified product portfolio, AKG is able to deliver solutions for the entire thermal demands of the vehicle and reaches highest efficiency through matching all the components to each other.

Our thermal management system connects LightWeight cooler (Tube fin cooler) for coolant cooling, compact cooler for thermal storage, hydraulic & transmission oil cooling and liquid cooled cold plates for various power electronic components as well as for batteries.

### Applications

- Agricultural machinery
- Automotive
- Commercial vehicles
- Construction machinery
- Forestry machinery
- Generator sets
- Municipal vehicles
- Rail vehicles

### Benefits

- Extended range
- Increased battery life
- Fast charging
- Full climate control
- Environmental friendly refrigerant

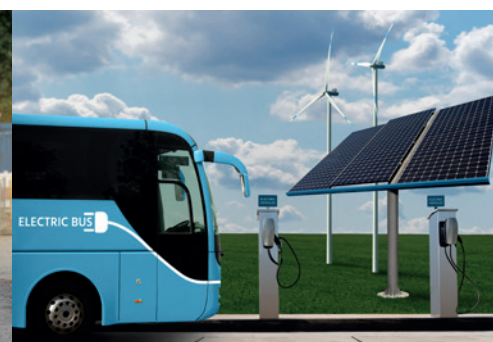
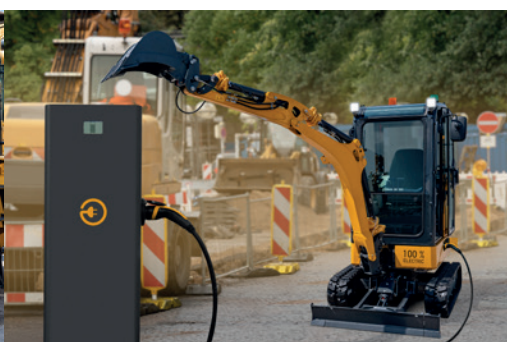

## Cooling System for Fuel Cell Vehicles



Coolant Cooler



Low Conductive Coolant Cooler



Charge Air Cooler



Hydrogen Pre-heater

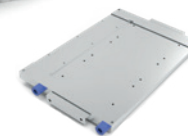

Power Electronics Cooling

Next to low conductive coolant coolers, AKG has a wide range of heat exchangers for fuel cell cooling applications. These solutions include a LightWeight cooler (Tube fin cooler) for coolant cooling, liquid cooled cold plate for power electronics and liquid cooled compact coolers for hydrogen pre-heating & charge-air cooling. AKG's technical expertise in integrating different systems do not only offers a flexible design to our customers, but is also meeting all the demands of fuel cell applications.

## Applications

- Agricultural machinery
- Automotive
- Commercial vehicles
- Construction machinery
- Forestry machinery
- Generator sets
- Municipal vehicles
- Rail vehicles

## Benefits of indirect vs. direct circuit

- Conductive particles are reduced as the circuit is smaller sized
- Reduced volume of expensive low conductive coolant
- Less ionic emissions resulting in lower change interval for ion exchanger
- Components of the coolant circuit can be produced with less requirements complying with electrical conductivity





## AKG Thermotechnik International GmbH & Co. KG

Am Hohlen Weg 31

D-34369 Hofgeismar • Germany

Phone + 49 5671 - 8 83 - 0

[info@akg-group.com](mailto:info@akg-group.com)

[www.akg-group.com](http://www.akg-group.com)



## AKG GROUP – A STRONG GLOBAL COMPANY

*AKG is a leading global supplier of high-performance coolers and heat exchangers, providing custom system solutions with the highest quality standards.*

*Around the world 3,150 employees work at 11 manufacturing facilities located in Germany, France, Latvia, Turkey, the USA, Mexico, Brazil, China and India. Together with a number of sales offices in additional countries and regions, AKG's cooling experts are on duty around the clock.*

*Longstanding partnerships with global OEM customers from 24 lines of business - including construction machinery, compressed air systems, agricultural and forestry machines, and many others - give fresh and innovative inspiration for AKG's line of pre-engineered cooling systems as well.*

*AKG operates one of the world's largest research, development, measurement and validation centres for cooling solutions and customized applications.*

*For over 100 years, AKG's heat exchangers have stood for innovative solutions as well as the highest standard of engineering and manufacturing expertise.*